

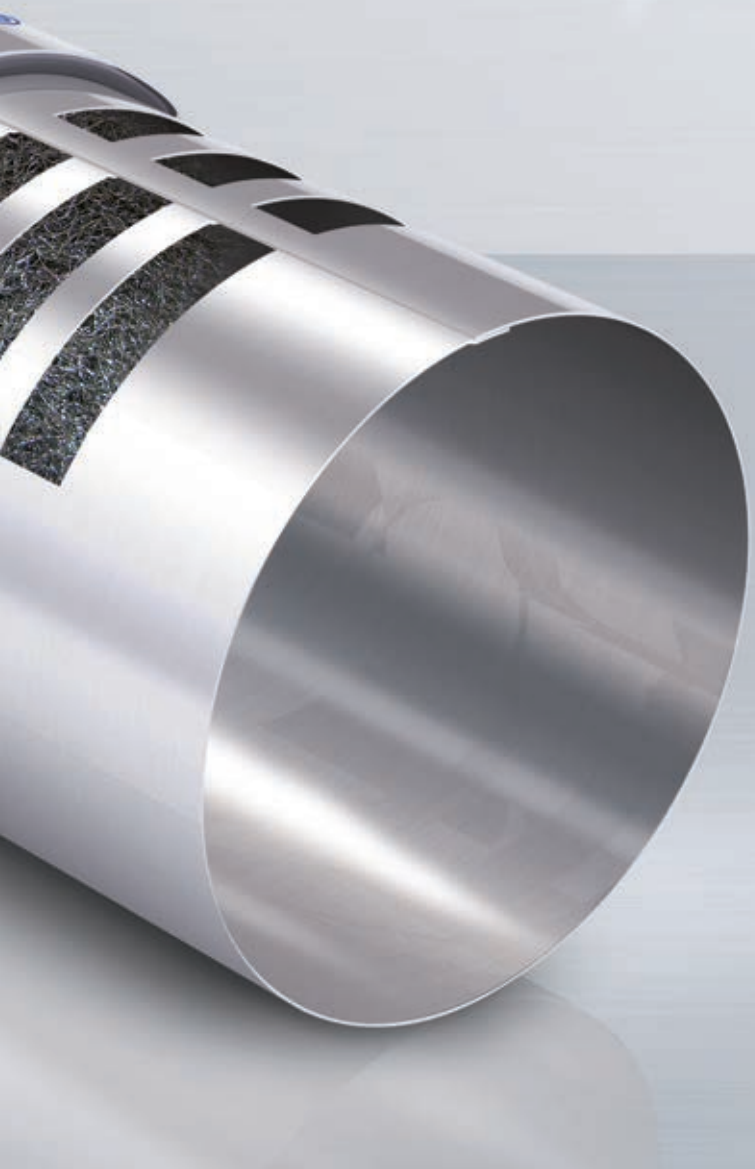

## REVEN® Pipe Series

Condenser for the X-C YCLONE® C and CE series



**REVEN**®  
**X-CYCLONE**  
**Air Cleaner**  
**Luftreiniger**



## RANGE OF APPLICATION

---

Compact condensation system for steam and oil vapours, suitable accessory for the X-CYCLONE® C and CE series.

## TECHNICAL HIGHLIGHTS

---

- Efficient condensation system made of stainless steel.
- Efficient air guidance straight to the condenser.
- Sustainable air-cleaning concept thanks to the use of cleanable components.
- Enclosure, condenser and all control elements 100 % rustproof in accordance with the requirements of the German trademark association for stainless steel Warenzeichenverband Edelstahl Rostfrei e.V.
- Designed, constructed and produced in Germany.
- Lifetime guarantee on the corrosion resistance of the enclosure.



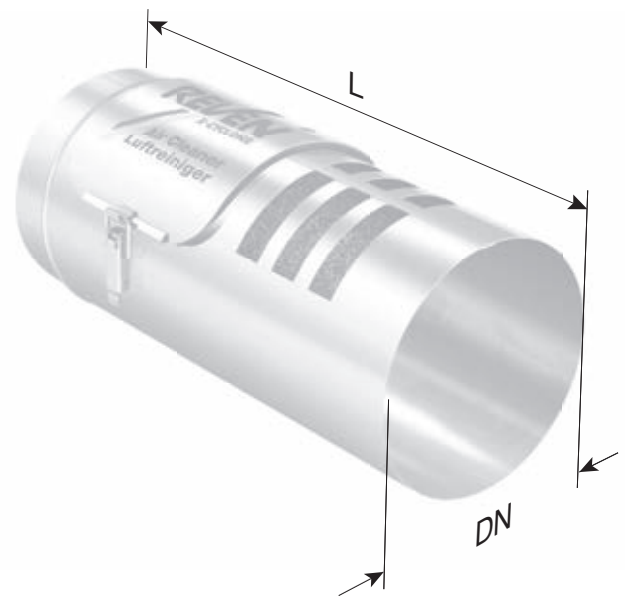

#### TECHNICAL DATA – REVEN® PIPE SERIES

Type of device	Extraction volume [m <sup>3</sup> /h]	Length [mm]	Connecting diameter [mm]	Weight [kg]
Pipe 1	800	400	150	3
Pipe 2	1700	400	200	5
Pipe 3	4000	400	300	8
Pipe 4	5000	400	400	12